



STARS *Interstellar Nano Adventure*
June 11-22, 2007

OLYMPIAD

TEAM : _____





The Mission

Your mission, if you choose to accept it, is to collect geological samples from a Planet X. You will map the area and create the best path to get to the collection site. Once you are at the collection site, you will collect a sample of rock formation. You will bring the sample back to Earth, where it will be analyzed by NASA scientists. Be prepared to use all of the skills that you learned during your two week training.

BEWARE

This mission may be difficult and dangerous...be safe, be careful.

Good luck,

*From all of us at Mission
Control*

USF STARS: AN NSF GK12 PROGRAM

SPACE JAM

Olympiad: Mission Space

OLYMPIAD
Mission
Manual

Pilot

Commander

Power Specialist

Mission Specialist

Biology Specialist

Communication Specialist

Payload Specialist

Geology Specialist

Robotics Specialist

Science Specialist

CREW CONTRACT

Before your crew can accept this mission, you must agree to the following:

1. Your crew must keep the mission a secret. Do not communicate with other competing crews.
2. Your crew must complete each mission successfully before moving on to the next one.
3. Your missions will take place in different rooms of the space station. Travel from room to room is only possible by space walks. Therefore, you must keep your spacesuit on under all circumstances.
4. Remember, travel from room to room is only possible by space walks. When doing your space walks as a crew, remain quiet. Speaking is ONLY permitted once your spacewalk is complete (that is, once you enter the room).
5. As a crew you must pledge to:
I, a member of the _____ crew, pledge to the success of my crew's mission. I promise to help my crewmembers with the mission; I promise to be a team player; and I promise to uphold the procedures set forth in this contract.

DATE _____

CREW SIGNATURES



Mission Introductions and Objectives

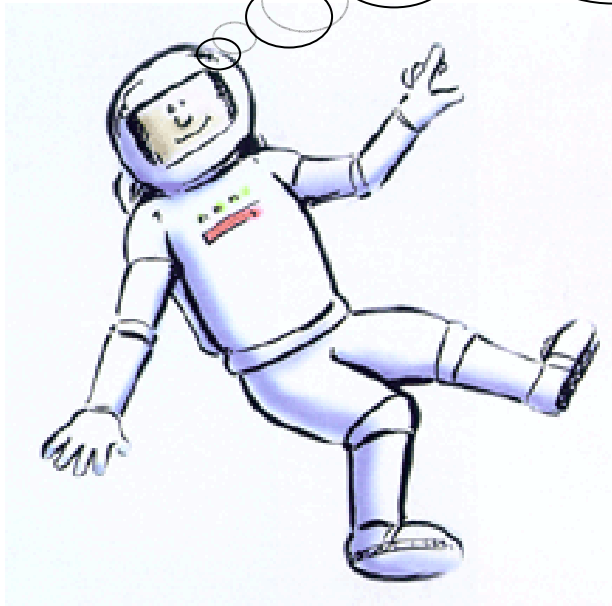

USF STARS: AN NSF GK12 PROGRAM

SPACE JAM

Mission 1: Rocket Launch

Introduction: The proper design and launching of rocket ships are important to the success of space missions. The rocket ship should be designed to minimize air resistance. The launching of the rocket ship must be powerful enough to propel the rocket into outer space.

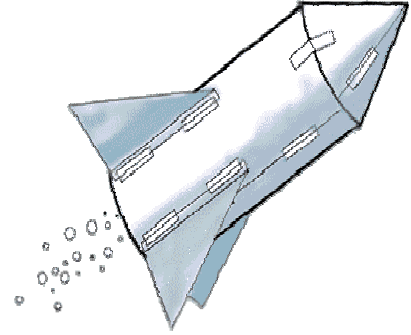

Objective: To build a rocket and launch it into space!

Mission 2: Space Suit

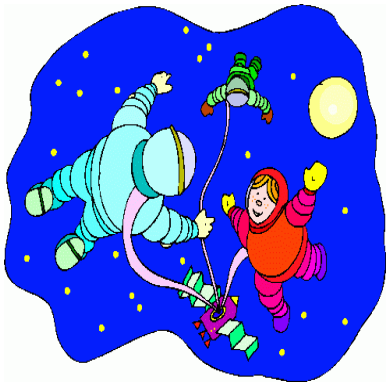

Introduction: In order for astronauts to do space walks, they must wear space suits. These special suits provide oxygen, protection from high temperatures, and protection from radiation.

Objective: To construct a space suit.

Mission 3: Power Trouble!!

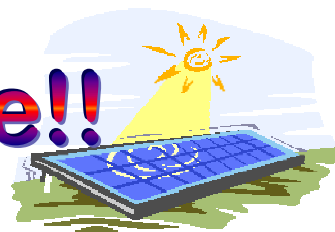

Introduction:

Rocket ships require power in order to function properly. There are numerous meters and monitors on the ship that require power. If a rocket ship loses power, the problem must be resolved quickly. Solar cells provide a solution for this problem because they work by converting solar energy into power for space missions.

Objective: To build a solar cell as an alternative power source.

USF STARS: AN USF 6K12 PROGRAM

SPACE JAM
Olympiad: Mission Space

Mission 4: Radio Down!

Introduction:

Communication between astronauts and mission control is crucial to the success of a mission. Mission control is composed of engineers and technicians who monitor and double-check the movements of the crew and the spacecraft. They provide help during unexpected situations. Binary communication, which uses only the numbers 1 and 0 instead of letters, can be utilized to send messages. These messages are sent using electrical signals from the spacecraft to mission control.



Objective: To relay a message to mission control.

Mission 5: Topo Map

Introduction: Topographic maps, or "topo maps", show mountains and valleys on a flat piece of paper. Topo maps are handy and necessary for many uses, including locating a region of interest for exploration purposes.



Objective: To use a topo map to find the best path to the geological site.

USF STARS: AN USF 6K12 PROGRAM

SPACE JAM
Olympiad: Mission Space



Mission 6: Digging up Geological Samples

Introduction:

One of the most important aspects of space exploration is obtaining geological samples for testing. Testing these samples can provide information on a planet, such as the climate, and whether certain elements exist. The results from these tests could potentially provide answers to questions concerning the evolution of planets.

Objective: To obtain a geological sample for testing.

Mission 7: Coming Home!

Introduction:

The voyage home is a very dangerous aspect of space travel. The spacecraft must be designed to protect the astronauts from the extreme conditions during re-entry.

Objective:

To construct a module of a spacecraft that can withstand the extreme conditions encountered during re-entry.



USF STARS: AN NSF GK12 PROGRAM

SPACE JAM
Olympiad: Mission Space

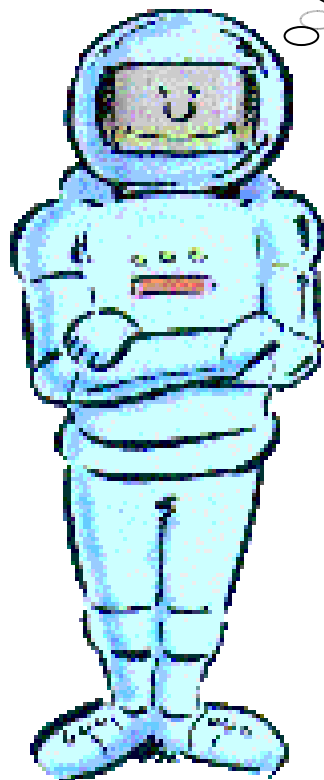

USF STARS: AN NSF GK12 PROGRAM

SPACE JAM

OLYMPIAD
Mission
manual

Mission 1



3 2 1

BLAST OFF!



Your crew must build the rocket!

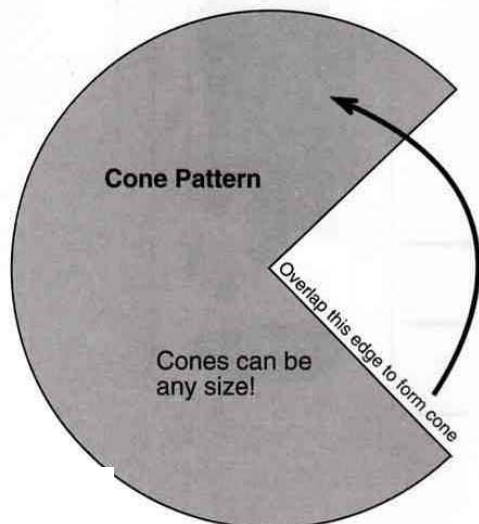
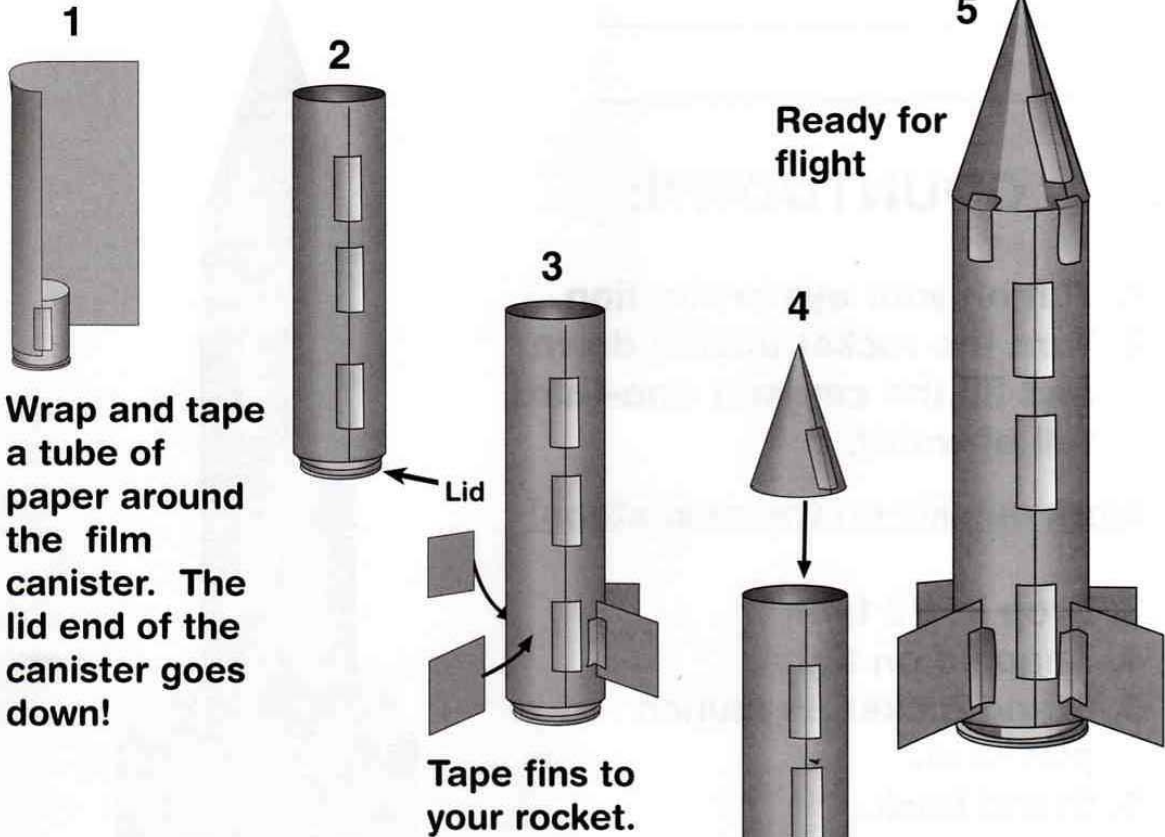

Roll a cone of paper and tape it to the rocket's upper end.



3
2
1

BLAST OFF!



In this mission, your crew will build a rocket and launch it. Follow the directions on the mission poster.

Hypothesis: Which trial does your crew think will fly the highest?

Fly the rocket 3 times

What happened?

Trial 1 Once with the canister full of water

Trial 2 Once with the canister $\frac{1}{2}$ full of water

Trial 3 Once with the canister $\frac{1}{4}$ full of water

| |
|--|
| |
| |
| |

Try to make it fly over your team leader's head!

Which trial flew the highest?

Why?

Password

OLYMPIAD
Mission
Manual

Mission 2



Spacesuit Build

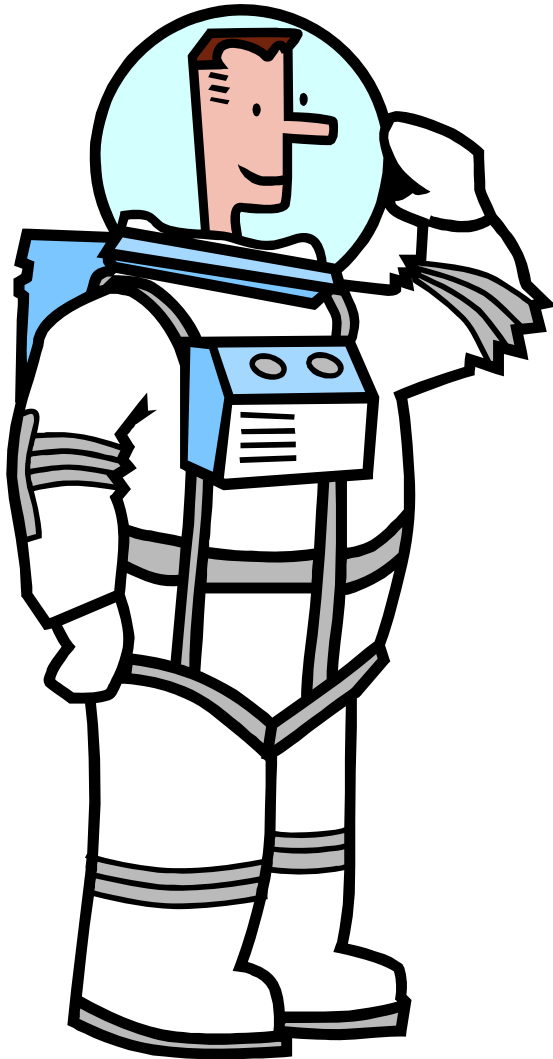

Uh-oh! Mission Control forgot to pack your spacesuits in the shuttle before your lift-off! It is your job to make your own spacesuits. Show them to the mission representative. Before you can move on to the next mission, your entire crew must have completed their suits.

Question

Why is it important for an astronaut to wear a space suit? Give at least 3 reasons.

Password

OLYMPIAD
Mission
Journal

Mission 3



POWER TROUBLE



With the following materials and instructions, your crew will build a solar power source for the shuttle.

Be careful, only one crew member can handle the copper and that crew member MUST wear gloves!

Materials:

Salt

Water

Gloves

Ruler

2 pieces – half a square foot of copper (one treated and one not treated)

1 – 2 liter clear plastic bottle

2 – alligator clips

1 – microammeter



1. While wearing the gloves, bend both pieces of copper gently, so they will fit into the plastic bottle or jar without touching one another.
2. Face the smoothest sides outward in the jar.
3. Attach the two alligator clip leads, one to the new copper plate, and one to the treated plate.
4. Connect the lead from the clean copper plate to the positive terminal of the meter. Connect the lead from the cuprous oxide plate to the negative terminal of the meter.



- Carefully pour the saltwater into the jar, being careful not to get the clip leads wet.
- Leave about an inch of plate above the water, so you can move the solar cell around without getting the clip leads wet.

Questions

How much current was produced in normal light?
Record you much electricity was created.

How much current was produced in the high intensity light? Record you much electricity was created.

Explain how the energy was produced.

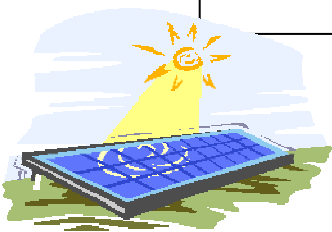

Password

OLYMPIAD
Mission
maneuver

Mission 4

OLYMPIAD
Mission
Journal

Mission 5



MAPPING YOUR PATH



Follow the directions on the topo map of Hilly Planet. Use the diagrams on the next page to guide you along your path.

Questions

How many hills are greater than 400 km high?

Define topographic map.

Why is it important to know the topography (mountains, valleys) of the planet when planning the mission?

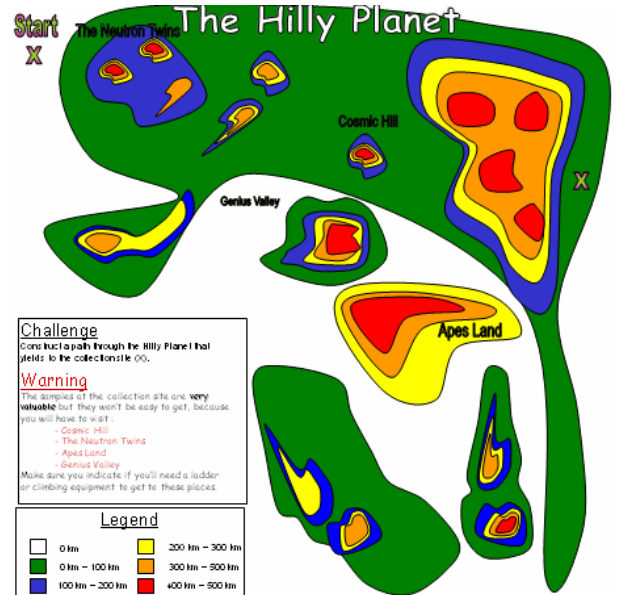
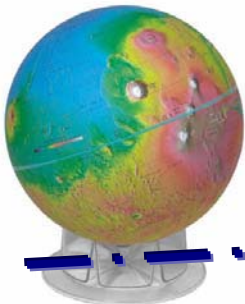

Password



MAPPING YOUR PATH



Use the following pictures to define your path along the topographic map. Cut them out and place them where you think they should go.

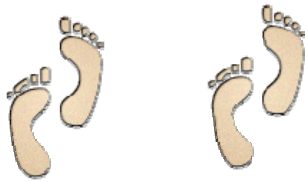

OLYMPIAD
Mission
REARVIEW

Mission 6



DIGGING IT UP



Use the radio controlled planet rover to bring the samples from the collection site. Lead the rover to the collection site, then using the robotic arm pick them up from the ground and place them on the rover. Bring the rover back to your location. Once the samples are at your location, place them in the sample bags. You will bring the sample back to Earth, where it will be analyzed by NASA scientists.



Good luck, be careful with the samples as they are very fragile and may break easily. Show your samples to the mission representative for approval.

Why is it important to have samples from other planets?

What is a robotic arm?

Password

OLYMPIAD
Mission
manual

Mission 7



COMING HOME



Design your escape pod and parachute in the box.



How did you cushion the escape pod?

What materials did you use and why?



COMING HOME



What is the purpose of the parachute?

Did you have fun while you were learning during this camp?

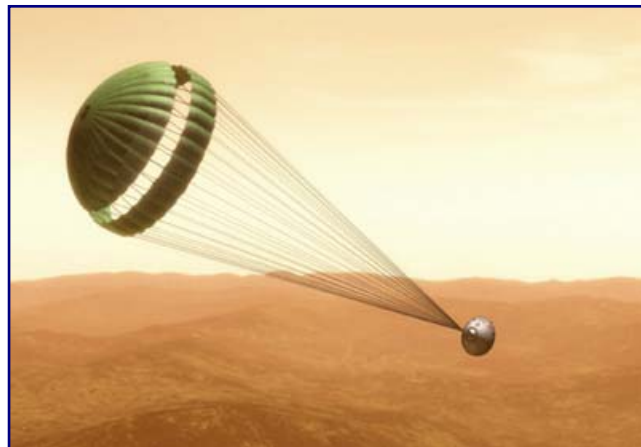

Password

SPACE JAM

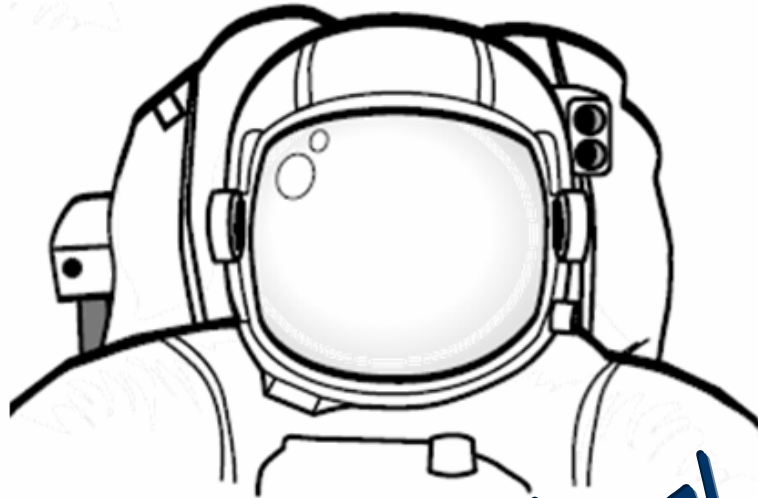

Congratulations!
Mission Accomplished!

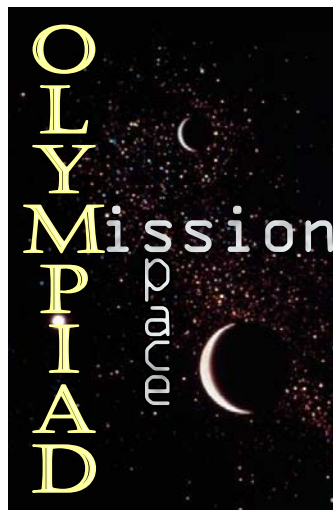

USF STARS: AN NSF GK12 PROGRAM

SPACE JAM